



## Air & Road Conditions (ARC) WCM-02 Installation and Operation Manual

### Product Description

The PreCise® ARC System, WCM-02, is a remote in-cab display designed to connect to a wired or wireless ARC sensor. The display collects accurate road and air conditions information from the sensors and presents the information to the user on an intuitive, easy-to-read screen. Easily view and collect data critical to decision making including relative humidity, dew point, air temperature and road temperature.



### Features

- Sunlight readable, full color display
- Backlight: User selectable and auto-dimming
- Display Units: °C or °F, User selectable
- Update Frequency: 1 to 60 seconds, User selectable
- Power: 9.8V-32V vehicle power
- Serial Interfaces: RS-232, SAE J-1708, CAN



## Warnings & Cautions



- Read and follow all safety rules and instructions before installing or operating this equipment.
- Never operate a vehicle within a closed area. Always assure proper ventilation before starting engine.
- Always use eye protection. Use goggles that are ANSI approved against impacts and shattering.
- Before wiring, disconnect the negative cable from the battery terminal. Failure to do so may result in electric shock or injury due to electrical shorts. Batteries can generate explosive gases. Keep sparks, flames and smoking materials away from batteries. Always wear eye protection around batteries.
- Do not damage pipe or wiring when drilling holes. When drilling holes in the chassis for installation, take precautions so as not to contact, damage or obstruct pipes, fuel lines, tanks or electrical wiring. Failure to take such precautions may result in fire.
- Do not use bolts or nuts in the brake or steering systems to make ground connections. Bolts or nuts used for the brake or steering systems (or any other safety-related system), or tanks should NEVER be used for installations or ground connections. Using such parts could disable control of the vehicle and cause fire etc.
- Arrange the wiring so it is not crimped or pinched by a sharp edge. Route the cables and wiring away from moving parts (like the seat rails) or sharp or pointed edges. This will prevent crimping and damage to the wiring. If wiring passes through a hole in metal, use a rubber grommet to prevent the wires insulation from being cut by the metal edge of the hole.
- When making connections to the vehicle's electrical system, be aware of the factory installed components (e.g. on-board computer). Do not tap into these leads to provide power for this unit. When connecting the unit to the fuse box, make sure the fuse for the intended circuit has the appropriate amperage. Failure to do so may result in damage to the unit and/or the vehicle.
- Be sure to connect the color coded leads according to the diagram. Incorrect connections may cause the unit to malfunction or damage to the vehicle's electrical system.
- To avoid property damage, personal injury, or death, park the vehicle on a flat level surface, set the parking brake, turn the engine off, and chock the wheels before beginning installation.
- Do not mount the module in a location that could interfere with proper operation of the vehicle, such as behind the gas or brake pedals.
- Avoid any circuits associated with the airbag system. Inadvertent airbag deployment may cause personal injury or death.

# INSTALLATION INSTRUCTIONS

## Before You Start

Prior to installing the PreCise® ARC sensor and display, take time to familiarize yourself with the installation instructions, theory of operation, and system components. Check the contents of the shipping package and verify the display and appropriate harness are included.

## Mounting Locations

Select a mounting location that allows the operator to see the display without distracting from the safe operation of the vehicle. The mounting surface should be relatively flat and smooth. Prior to attaching the adhesive strips, ensure the mounting surface is clean and free from contaminants.

## Electrical Connections

The WCM-02 is designed to operate from switched 9.8-32Vdc power. It should typically be connected to the ignition signal so that the display is on when the vehicle is running, and off otherwise.

**An in-line fuse, rated for three or five amps should be used for the ignition connection. Under no circumstances should this connection be made directly to vehicle power without fuse protection.**

The red wire from the harness should be connected to switched power, and the black wire should be connected to battery negative or chassis ground.

If a wired sensor (TS-01) is being installed, connect the M8 extension cable to the M8 connector on the harness.

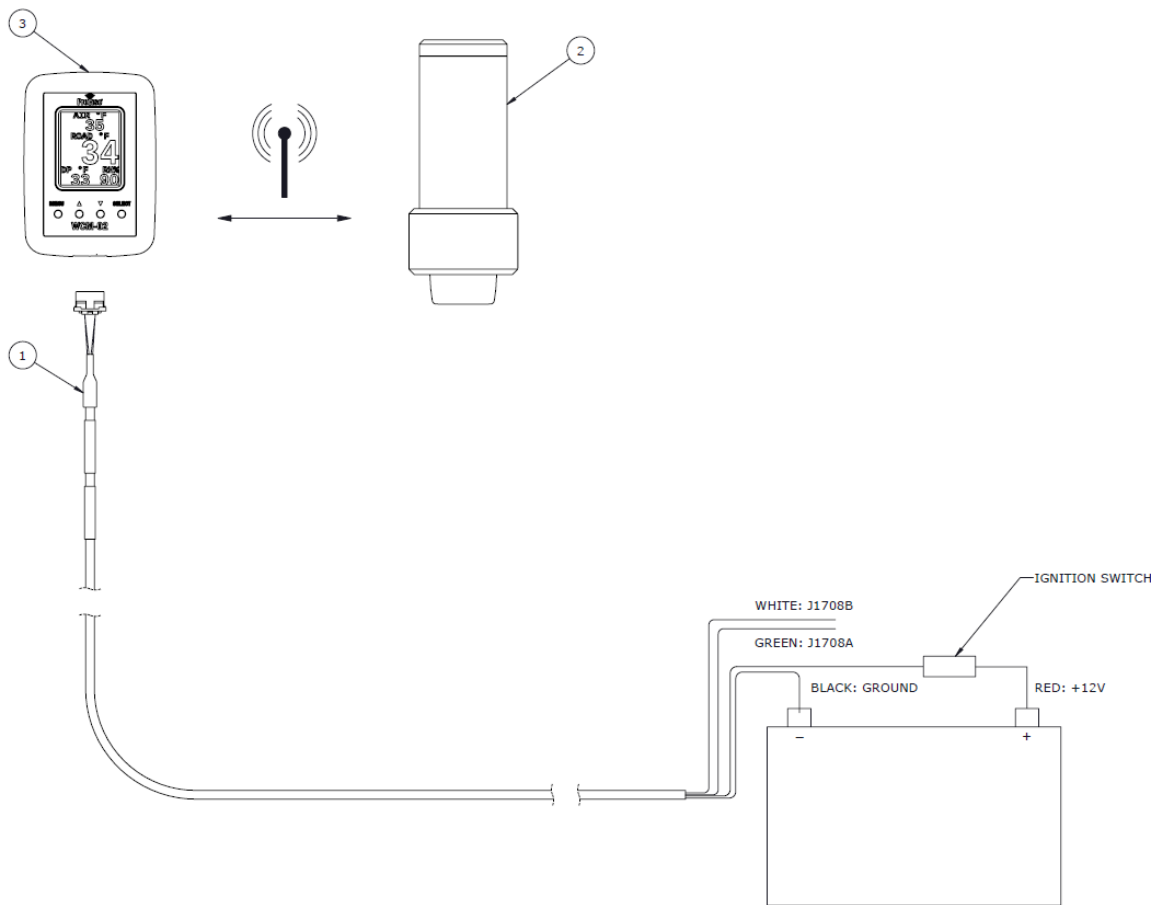

Figure 1: Wiring for WTS-01

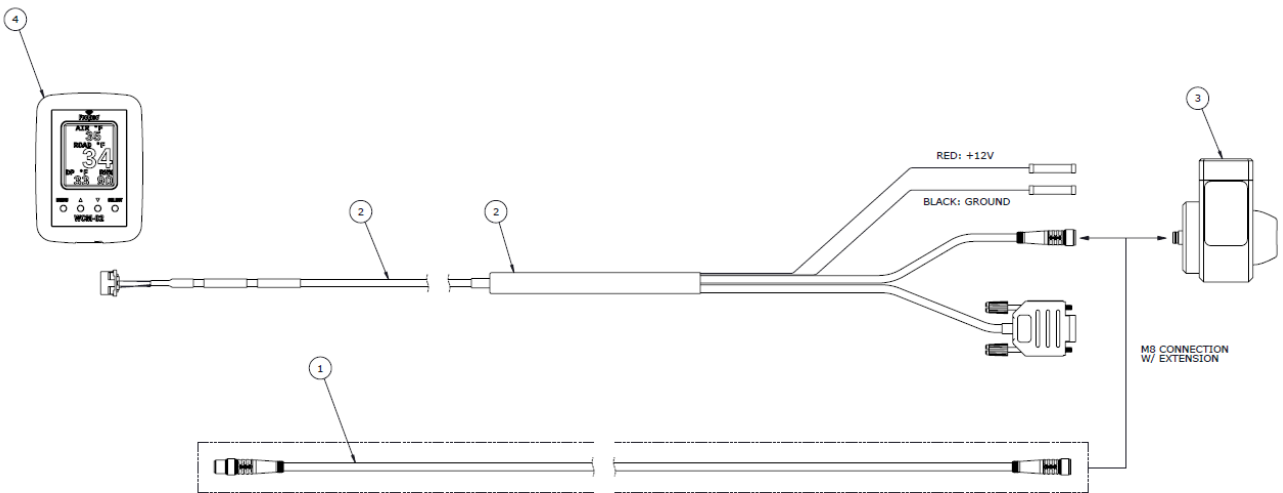
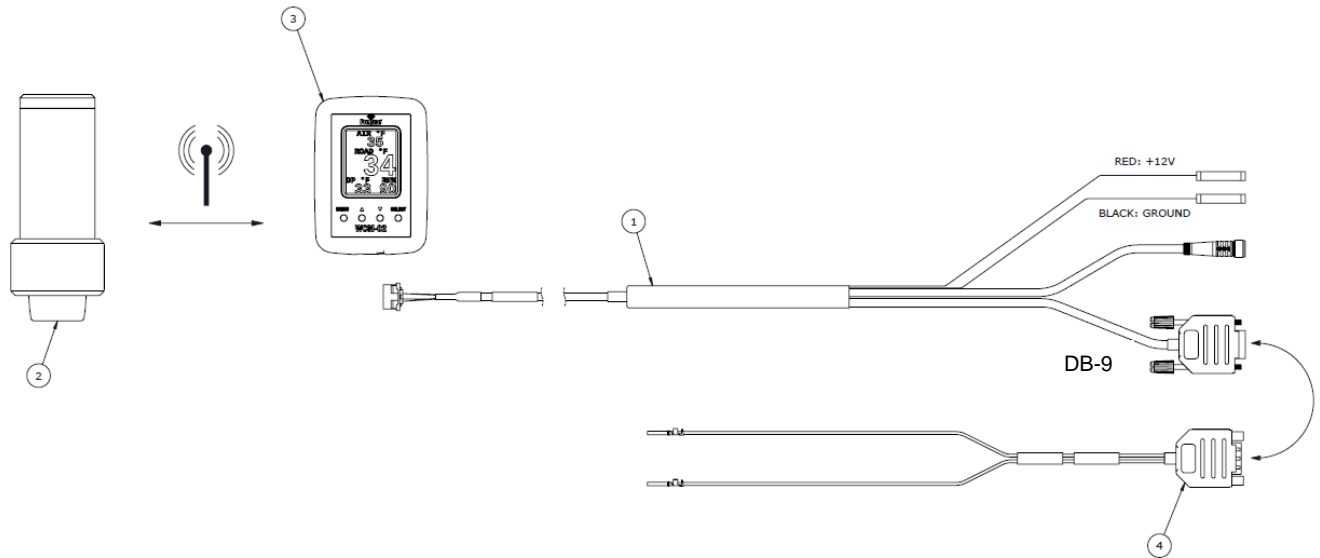

Figure 2: Wiring for TS-01

To interface the RS-232 output to an IX-403-H, connect the DB-9 connector on the display harness to the appropriate connector on the IX-403-H. To interface the RS-232 output to an IX-101-H, a DB-9 pigtail harness will need to be added to the IX-101-H connector if it does not currently have one. The green wire should be inserted in position 6 of the IX-101-H connector. The white wire should be inserted in position 7.



**Figure 3: Connections for IX-101**

For questions regarding installation or operation, please contact PreCise Support at 888-254-1634 during normal business hours (7AM-6PM Mountain Time, Monday-Friday) or [support@precisemrm.com](mailto:support@precisemrm.com).

## Main Display

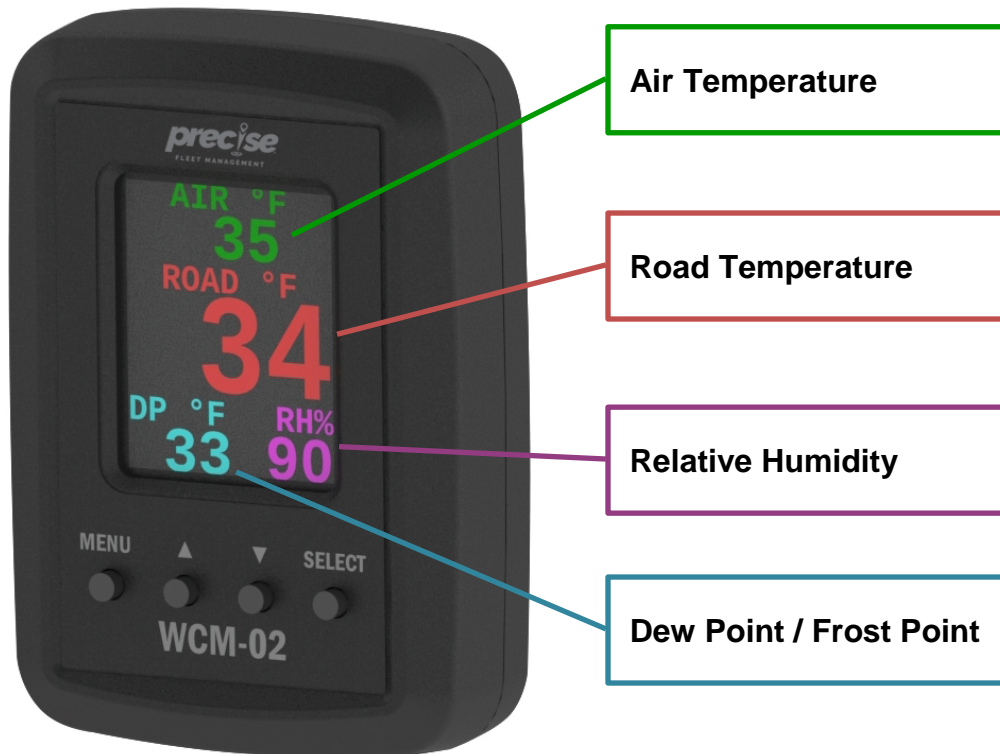

## Display Options

### Pairing Sensor to Display

The first time a sensor and display are installed or if either is replaced, they will need to be paired.

- Hit the MENU button.
- Use the UP (▲) and DOWN (▼) buttons to underline “Sensor Selection”.

```
Temperature  
Brightness  
Configuration  
Signal Strength  
Sensor Selection  
Report Interval  
Accel Settings|  
Wake Interval
```

- Hit the SELECT button.
- With “Scan sensors” underlined, hit SELECT again.

```
Scan sensors  
Select none
```

- While the display shows “Scanning” install the battery in the sensor or tap it a few times to wake it up. If you are pairing to a wired sensor, it will transmit as long as it has power.
- When you see the serial number of the sensor you are pairing, underline it with the UP (▲) and DOWN (▼) buttons and hit SELECT.

```
Scanning 1 of 2  
02D023804A34940E  
020C522028503007
```

- With “Temperature” underlined, hit SELECT. This will take you to the main display screen showing air and road temperature, as well as dewpoint (or

frostpoint) and relative humidity. Note that it could take up to a couple of minutes before data from a wireless sensor appears.

```
Temperature  
Brightness  
Configuration  
Signal Strength  
Sensor Selection  
Report Interval  
Accel Settings  
Wake Interval
```

### Brightness Control

The brightness of the display can be controlled in a few ways. Even after power is removed from the display, it will remember the last setting.

- From the main display screen, simply hit the UP (▲) or DOWN (▼) buttons to increase or decrease the brightness.
- Alternatively, hit the MENU button, underline “Brightness”, and hit SELECT.

```
Temperature  
Brightness  
Configuration  
Signal Strength  
Sensor Selection  
Report Interval  
Accel Settings  
Wake Interval
```

- From this screen, you can select a set level or “Brightness AUTO”, which will automatically adjust the brightness level based on ambient light conditions. Underline your choice and hit SELECT. This will take you back to the main display screen.



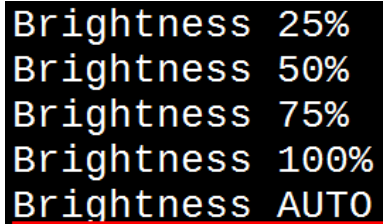

```
Brightness 25%
Brightness 50%
Brightness 75%
Brightness 100%
Brightness AUTO
```

### Units Configuration (°F or °C)

Once the configuration is selected, the setting is saved until the next time it is changed.

- Hit the MENU button.
- Use the UP (▲) and DOWN (▼) buttons to underline “Configuration”.

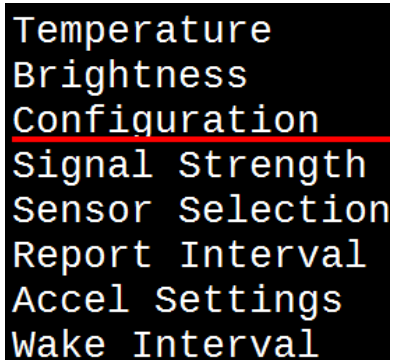

```
Temperature
Brightness
Configuration
Signal Strength
Sensor Selection
Report Interval
Accel Settings
Wake Interval
```

- Hit the SELECT button, then underline the desired units and hit SELECT again. This will take you back to the main display screen.

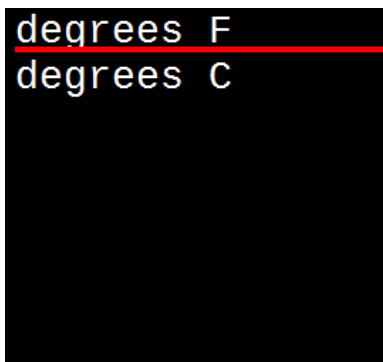

```
degrees F
degrees C
```

## Report Interval

The time between temperature and humidity readings from the wireless sensor (WTS-01) is controlled with this setting. The wired sensor (TS-01) will report every second, regardless of this setting. Once the interval is selected, the setting is saved until the next time it is changed.

- Hit the MENU button.
- Use the UP (▲) and DOWN (▼) buttons to underline “Report Interval”.

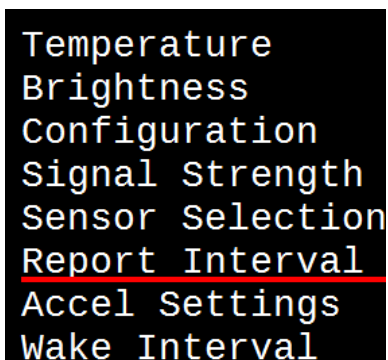

- Hit the SELECT button, then increment or decrement the interval with the UP (▲) and DOWN (▼) buttons. Hit SELECT again. This will take you back to the main display screen.

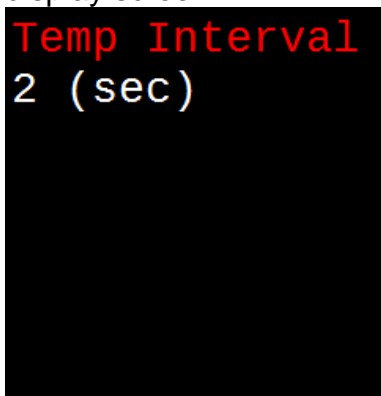

## Wake Interval

The wireless sensor (WTS-01) will “wake up” and determine if its paired display is on, based on sensing movement via the built-in accelerometer and periodically based on the wake interval. The wired sensor (TS-01) will report as long as it has power, regardless of this setting. Once the interval is selected, the setting is saved until the next time it is changed.

- Hit the MENU button.
- Use the UP (▲) and DOWN (▼) buttons to underline “Wake Interval”.

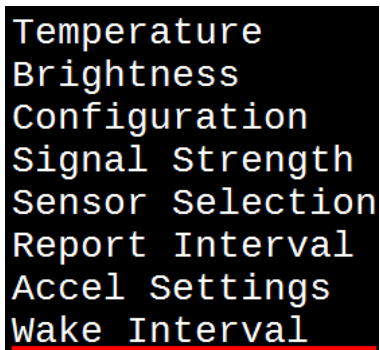

Temperature  
Brightness  
Configuration  
Signal Strength  
Sensor Selection  
Report Interval  
Accel Settings  
Wake Interval

- Hit the SELECT button, then increment or decrement the interval with the UP (▲) and DOWN (▼) buttons. Hit SELECT again. This will take you back to the main display screen.

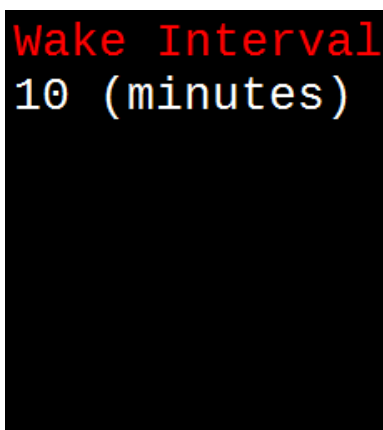

Wake Interval  
10 (minutes)

## Accel Settings

The wireless sensor (WTS-01) will “wake up” and determine if its paired display is on, based on sensing movement via the built-in accelerometer and periodically based on the wake interval. The wired sensor (TS-01) does not have an accelerometer. This screen will show the latest accelerometer readings in each axis, as well as the peak readings. Additionally, it will show the number of times the sensor has been brought out of sleep mode by the accelerometer without the display being on.

- Hit the MENU button.
- Use the UP (▲) and DOWN (▼) buttons to underline “Accel Settings”.

```
Temperature
Brightness
Configuration
Signal Strength
Sensor Selection
Report Interval
Accel Settings
Wake Interval
```

- Hit the SELECT button.

```
X0 Y0 Z1
PK1 1 1

Acc false starts
0
```

- To clear the peak and false start readings, hit the SELECT button, underline “yes” and hit SELECT again. To return to the menu screen, hit the MENU button.

## Accel Threshold

The wireless sensor (WTS-01) will “wake up” and determine if its paired display is on, based on sensing movement via the built-in accelerometer and periodically based on the wake interval. The wired sensor (TS-01) does not have an accelerometer. If the accelerometer detects movement above the threshold setting, it will wake the sensor. The higher the setting, the more force will be required to wake the sensor.

- Hit the MENU button.
- Use the DOWN (▼) buttons to scroll past the bottom of the screen and underline “Accel Threshold”.

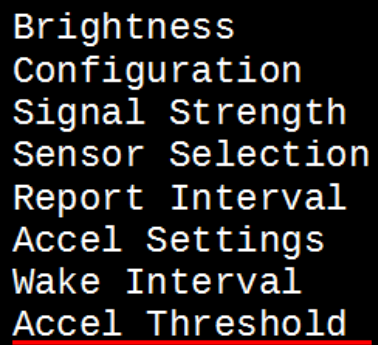

```
Brightness
Configuration
Signal Strength
Sensor Selection
Report Interval
Acce1 Settings
Wake Interval
Acce1 Threshold
```

- Hit the SELECT button, then increment or decrement the threshold with the UP (▲) and DOWN (▼) buttons. Hit SELECT again. This will take you back to the menu screen.



```
Acce1 Threshold
3
```

## MANUFACTURER LIMITED WARRANTY AND LIMITATION OF LIABILITY

Manufacturer warrants that on the Date of Purchase this Product will conform to Manufacturer's published specifications for the product, which are available from Manufacturer on request, and Manufacturer warrants that the product is free from defects in materials and workmanship. This Limited Warranty extends for twelve (12) months from the date of delivery. Manufacturer will, at its option, repair or replace any product found by Manufacturer to be defective and subject to this Limited Warranty.

This Limited Warranty does not apply to parts or products that are misused; abused; modified; damaged by accident, fire or other hazard; improperly installed or operated; or not maintained in accordance with the maintenance procedures set forth in Manufacturer's Installation and Operating Instructions.

To obtain warranty service, you must ship the product(s) to the specified Manufacturer location within thirty (30) days from expiration of the warranty period. Contact customer service to obtain a RMA number and write the number on the shipping container. You must prepay shipping charges and use the original shipping container or equivalent. Return shipping charges within the United States, Canada, and Puerto Rico, will be paid by Manufacturer. This Limited Warranty will apply only to a product purchased and located in the United States, Canada, or Puerto Rico.

**EXCLUSION OF OTHER WARRANTIES:** MANUFACTURER MAKES NO OTHER WARRANTIES, EXPRESSED, IMPLIED OR STATUTORY. THE IMPLIED WARRANTIES FOR MERCHANTABILITY AND FITNESS FOR A PARTICULAR PURPOSE ARE HEREBY EXCLUDED AND SHALL NOT APPLY TO THE PRODUCT. BUYER'S SOLE AND EXCLUSIVE REMEDY IN CONTRACT, TORT OR UNDER ANY OTHER THEORY AGAINST MANUFACTURER RESPECTING THE PRODUCT AND ITS USE SHALL BE THE REPLACEMENT OR REPAIR OF THE PRODUCT AS DESCRIBED ABOVE.

**LIMITATION OF LIABILITY:** IN THE EVENT OF LIABILITY FOR DAMAGES ARISING OUT OF THIS LIMITED WARRANTY OR ANY OTHER CLAIM RELATED TO MANUFACTURER'S PRODUCTS, MANUFACTURER'S LIABILITY FOR DAMAGES SHALL BE LIMITED TO THE AMOUNT PAID FOR THE PRODUCT AT THE TIME OF ORIGINAL PURCHASE. IN NO EVENT SHALL MANUFACTURER BE LIABLE FOR LOST PROFITS, THE COST OF SUBSTITUTE EQUIPMENT OR LABOR, PROPERTY DAMAGE, OR OTHER SPECIAL, CONSEQUENTIAL OR INCIDENTAL DAMAGES BASED UPON ANY CLAIM FOR BREACH OF CONTRACT, NEGLIGENCE OR OTHER CLAIM, EVEN IF MANUFACTURER OR A MANUFACTURER'S REPRESENTATIVE HAS BEEN ADVISED OF THE POSSIBILITY OF SUCH DAMAGES. Manufacturer shall have no further obligation or liability with respect to the product or its sale, operation and use, and Manufacturer neither assumes nor authorizes the assumption of any other obligation or liability in connection with such product.

This Limited Warranty gives you specific legal rights, and you may also have other legal rights, which vary, from state to state. Some states do not allow the exclusion or limitation of incidental or consequential damages, so the above exclusion or limitation may not apply to you.

Any oral statements or representations about the product, which may have been made by salesmen or Manufacturer representatives, do not constitute warranties. This Limited Warranty may not be amended, modified or enlarged, except by a written agreement signed by an authorized official of Manufacturer that expressly refers to this Limited Warranty.

### Part 15 Notice:

This device complies with Part 15 of the FCC rules. Operation is subject to the following two conditions: (1) This device may not cause harmful interference, and (2) this device must accept any interference received, including interference that may cause undesired operation.